

Multipartite Nonlocality in Clifford Networks

Amanda Gatto Lamas^{1,*} and Eric Chitambar^{2,†}

¹*Department of Physics, University of Illinois at Urbana-Champaign, Urbana, IL 61801, USA*

²*Department of Electrical and Computer Engineering, Coordinated Science Laboratory,
University of Illinois at Urbana-Champaign, Urbana, IL 61801, USA*

(Dated: September 14, 2022)

In an N -party quantum network, non-classical correlations can arise when locally measuring across k -party entangled states ($k < N$) that are independently distributed. Such correlations are said to embody quantum network nonlocality. In this paper, we show that bipartite entanglement (i.e. $k = 2$) is sufficient for generating all forms of quantum network nonlocality when allowing for post-selection, a feature that might not arise when using more general non-signaling devices. We then demonstrate that network nonlocality fails to emerge in quantum networks limited strictly to pure stabilizer states and Clifford gates. This work sheds new light on the distinction between non-genuine and genuine network nonlocality by showing that all known approaches for generating the latter require some form of non-Clifford operation.

The Gottesman-Knill Theorem is a classic result that enables a wide class of quantum algorithms to be efficiently simulated [1–3]. It says that circuits constructed using only gates belonging to the Clifford group can be efficiently simulated on a classical computer using the stabilizer formalism. It is interesting to investigate whether Clifford quantum information processing has similar limitations for other quantum information tasks and phenomena, such as the emergence of quantum nonlocality. It has already been shown [4–7] that such limitations do indeed exist in specific scenarios, but the role of Clifford operations in the emergence of network nonlocality has remained relatively unexplored.

The study of quantum networks has recently intensified as a number of metropolitan-scale quantum networks are in plans for development or have already been constructed. New features and problems arise when considering quantum nonlocality with constrained connectivity between parties [8–12]. The standard Bell nonlocality scenario consists of multiple parties having access to some globally-shared entangled state, and they each select different measurements to perform on their respective subsystems [13]. In the network setting, the globally-shared entanglement is replaced by independent sources of entanglement and shared randomness that get distributed according to the structure of the network [12, 14].

Examples of nonlocality in networks have recently been found that appear to be fundamentally different than the nonlocality emerging in traditional Bell scenarios [15–20]. Conspicuously, in each of these examples some non-Clifford operation is needed to realize the nonlocality. This observation has motivated us to consider whether non-Clifford operations are truly necessary to generate genuine network nonlocality. We find that under proper assumptions this is indeed the case.

To describe our results in more detail, let us represent an N -party network by an n -node hypergraph $\mathcal{G} = (V, E)$ with n vertices $V = [n] := \{1, 2, \dots, n\}$ and hyperedge set $E \subset 2^{[n]}$. Each vertex represents a physical system,

and the vertices are partitioned such that party A_i locally controls a subset of n_i systems. The hyperedges connecting the vertices represent independent sources of shared correlation. In classical networks, the shared correlations are classical, and we associate each hyperedge $e \in E$ with the classical random variable λ_e that is accessible to all vertices in e . If the network is quantum, then the shared correlations can be in the form of quantum entanglement, and we associate each hyperedge $e \in E$ with a multipartite density matrix ρ_e that is shared between parties connected by e . More generally, one could consider multi-party non-signaling correlations distributed along each hyperedge [11, 21–26]. In all cases, we are interested in the total correlations that can be generated when each party A_i locally patches together whatever independent correlations it has received and outputs some binary sequence \mathbf{b}_i of length n_i .

In a classical network, party A_i jointly processes all its n_i received variables. The global correlation produced in this way is a random binary vector $(\mathbf{b}_1, \dots, \mathbf{b}_N) \in \mathbb{Z}_2^n$ with distribution

$$p(\mathbf{b}_1, \dots, \mathbf{b}_N) = \sum_{\vec{\lambda}} p(\vec{\lambda}) \prod_{i=1}^N p(\mathbf{b}_i | \bigcup_{\substack{e \\ i \in e}} \lambda_e), \quad (1)$$

where $p(\vec{\lambda}) = \prod_{e \in E} p(\lambda_e)$, and the summation is over all tuples $\vec{\lambda} = (\lambda_e)_{e \in E}$ of values realized by the $|E|$ independent random variables. We say a distribution over $(\mathbf{b}_1, \dots, \mathbf{b}_N) \in \mathbb{Z}_2^n$ is k -network local if it has the form of Eq. (1) for some hypergraph \mathcal{G} with $|e| \leq k$ for all $e \in E$; otherwise we say the distribution is k -network nonlocal.

In a quantum network, the λ_e are replaced by density matrices ρ_e and the local classical channels $p(\mathbf{b}_i | \bigcup_{e \in A_i} \lambda_e)$ are replaced by local quantum-to-classical channels, i.e. quantum measurements. The generated probability distributions are then given by

$$p(\mathbf{b}_1, \dots, \mathbf{b}_N) = \text{Tr} \left[\prod_{\mathbf{b}_1}^{A_1} \otimes \dots \otimes \prod_{\mathbf{b}_N}^{A_N} (\otimes_{e \in E} \rho_e) \right], \quad (2)$$

where $\{\Pi_{\mathbf{b}_i}^{A_i}\}_{\mathbf{b}_i}$ is a complete set of measurement operators for party A_i that act jointly on all the quantum systems distributed to vertex i , meaning that $\sum_{\mathbf{b}_i \in \mathbb{Z}_2^{n_i}} \Pi_{\mathbf{b}_i}^{A_i} = \mathbb{I}^{A_i}$ and $\Pi_{\mathbf{b}_i}^{A_i} \geq 0$ for all \mathbf{b}_i . We say a distribution over $(\mathbf{b}_1, \dots, \mathbf{b}_N) \in \mathbb{Z}_2^n$ is a *quantum k -network* distribution if it has the form of Eq. (2) for some hypergraph \mathcal{G} with $|e| \leq k$ for all $e \in E$. Any quantum k -network distribution failing to satisfy Eq. (1) is called *quantum k -network nonlocal*.

For $k = N$, every distribution $p(\mathbf{b}_1, \dots, \mathbf{b}_N)$ is k -network local. On the other hand, for $k = 1$ and arbitrary N , every quantum k -network correlated distribution is obviously also 1-network local. Therefore, one requires $N > 2$ to find quantum network nonlocality; i.e. it is a multipartite effect. Examples of quantum network nonlocality for $N = 3$ were reported in Ref. [15–19].

The primary goal of this paper is to place restrictions on the type of entangled states ρ_e and measurements $\{\Pi_{\mathbf{b}_i}^{A_i}\}_{\mathbf{b}_i}$ that must be performed to realize quantum network nonlocality. Below we show that all distributions are k -network local when generated using just Clifford gates and stabilizer states. We start by showing that every type of quantum k -network nonlocality can be obtained from quantum 2-network nonlocality through post-selection.

Proposition 1. Suppose that $p(\mathbf{b}_1, \dots, \mathbf{b}_N)$ is a quantum k -network nonlocal distribution for N parties. Then there exists an $(N + r)$ -party distribution $\hat{p}(\mathbf{b}_1, \dots, \mathbf{b}_N, \mathbf{x}_1, \dots, \mathbf{x}_r)$ that is quantum 2-network nonlocal and satisfies

$$p(\mathbf{b}_1, \dots, \mathbf{b}_N) = \hat{p}(\mathbf{b}_1, \dots, \mathbf{b}_N | \mathbf{x}_1 = 0, \dots, \mathbf{x}_r = 0). \quad (3)$$

In other words, conditioned on the new parties $\mathbf{X}_1, \dots, \mathbf{X}_r$ having the all-zero output, the other N parties reproduce the original distribution p .

A proof of this proposition is provided in the Appendix. The main idea is to replace every k -element hyperedge e with k bipartite edges, and then use bipartite entanglement distributed on these edges to teleport the original state ρ_e . We remark that our reduction to k -network nonlocality from 2-network nonlocality via post-selection is specific to quantum networks, as it relies on quantum teleportation. It is an interesting question whether such a reduction can be found for general non-signaling network correlations [27, 28] or whether this is a uniquely quantum feature.

Clifford Networks. We next introduce a wide class of quantum networks that can be understood as distributed Clifford circuits [1]. We begin by recalling the definitions of stabilizers and stabilizer operations [1, 29, 30]. Let \mathcal{P}_n denote the n -qubit Pauli group of operators, $\mathcal{P}_n = \{\pm 1, \pm i\} \times \{I, X, Y, Z\}^{\otimes n}$. Expressions like X_2 express Pauli- X applied to qubit 2 and the identity applied to all other qubits. The n -qubit Clifford group consists of all

unitaries that, up to an overall phase, leave \mathcal{P}_n invariant under conjugation,

$$\mathcal{C}_n = \{U \mid UgU^\dagger \in \mathcal{P}_n \quad \forall g \in \mathcal{P}_n\} / U(1). \quad (4)$$

The set of n -qubit stabilizer states is defined as

$$\mathcal{S}_n = \{U|0\rangle \mid U \in \mathcal{C}_n\}. \quad (5)$$

Every stabilizer pure state $|\varphi\rangle \in \mathcal{S}_n$ can be uniquely identified as the +1 eigenstate of n independent commuting elements from \mathcal{P}_n . These operators generate a group, called a stabilizer group, that we denote by $\text{stab}(|\varphi\rangle)$.

We next specify an operational model for generating network correlations within the stabilizer framework. Let us define a *Clifford k -network* for N parties to be a quantum network represented by a hypergraph $\mathcal{G} = ([n], E)$ in which each party can only perform a local Clifford gate and $|e| \leq k$ for all $e \in E$. A distribution $p(\mathbf{b}_1, \dots, \mathbf{b}_N)$ is a *Clifford k -network distribution* if it can be generated using the following procedure:

- (i) For each hyperedge $e \in E$ in some Clifford k -network, a stabilizer state $|\varphi_e\rangle$ is distributed to the qubits in e ;
- (ii) Each party A_i introduces m_i ancilla qubits initialized in state $|0\rangle$;
- (iii) Each party A_i performs a Clifford gate on the $n_i + m_i$ qubits held locally;
- (iv) Each qubit is measured in the computational basis.

Steps (i)–(iii) generate a stabilizer state $|\omega\rangle$ under the transformation $\bigotimes_{e \in E} |\varphi_e\rangle \rightarrow |\omega\rangle$ under local Cliffords (with ancilla), and step (iv) then extracts classical correlations from $|\omega\rangle$. Measurement of qubit j in the computational basis is characterized by the Pauli- Z observable Z_j , and whereas Z_j has eigenvalues $\{+1, -1\}$, for convenience we relabel these as $\{0, 1\}$. When party A_i measures each of its $n_i + m_i$ qubits, the measurement outcomes can then be described as a sequence of bits $\mathbf{b}_i \in \mathbb{Z}_2^{n_i + m_i}$, and the joint pmf for all measurements is given by

$$\begin{aligned} p(\mathbf{b}_1, \dots, \mathbf{b}_N) &= p(b_1, b_2, \dots, b_{n+m}) \\ &= \frac{1}{2^{n+m}} \langle \omega | \bigotimes_{i=1}^{n+m} (\mathbb{I} + (-1)^{b_i} Z_i) | \omega \rangle, \end{aligned} \quad (6)$$

where $m = \sum_{i=1}^N m_i$. As an example, a triangle Clifford network is depicted in Fig. 1. Its equivalent representation as a distributed quantum circuit is also shown.

Our main result is the following.

Theorem 1. Every Clifford k -network correlation is k -network local.

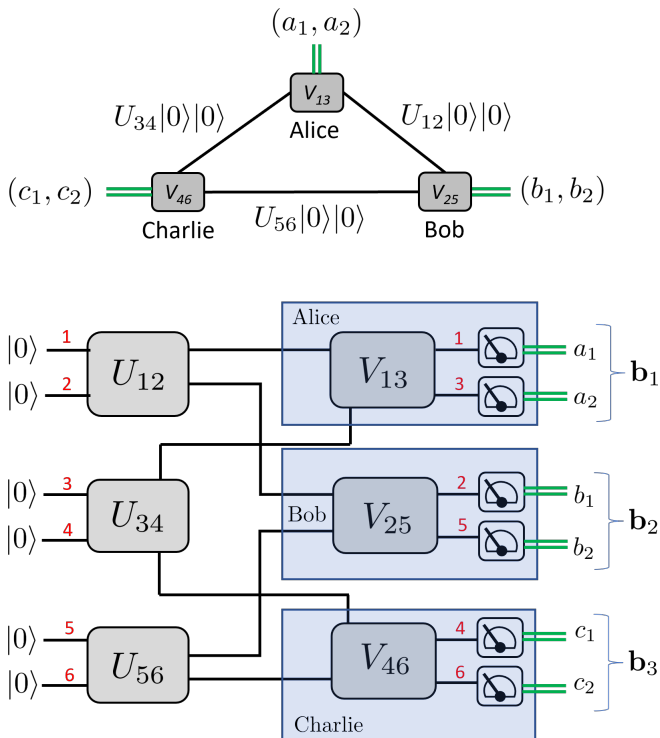

FIG. 1. The triangle network represented in the standard circuit model. The distribution over $(a_1, a_2, b_1, b_2, c_1, c_2)$ is a Clifford 2-network distribution if each of the U_{ij} and V_{ij} are Clifford gates.

Proof. We begin by performing three simplifications. First, in Proposition 1 we established that every quantum k -network nonlocal distribution can be obtained from a quantum 2-network nonlocal distribution via post-selection. Moreover, since teleportation is carried out using Pauli gates, the proof of Proposition 1 can be specialized to Clifford networks: if a quantum k -network nonlocal distribution is generated on a Clifford k -network, then there exists a quantum 2-network nonlocal distribution generated on a Clifford 2-network. Hence, to prove Theorem 1, it suffices to show that measuring Clifford 2-network states always leads to 2-network local distributions. In other words, we can restrict \mathcal{G} to just being a graph so that each $|\varphi_e\rangle$ is a bipartite stabilizer state. Second, recall the fact that every bipartite stabilizer state can be transformed into copies of $|\Phi^+\rangle = \frac{1}{\sqrt{2}}(|00\rangle + |11\rangle)$ and computational basis states $|0\rangle$ using local Cliffords [31]. Third, as proved in the Appendix, the use of local ancilla provides no advantage for the purpose of generating 2-network nonlocality. Then it suffices to consider graphs \mathcal{G} in which each node is connected to exactly one other node, the two nodes are held by different parties, and their connecting edge represents a maximally entangled state $|\Phi^+\rangle$ shared between them. We denote the corresponding graph state as $|\Phi_{\mathcal{G}}^+\rangle := \bigotimes_{e \in E} |\Phi_e^+\rangle$.

Once the state $|\Phi_{\mathcal{G}}^+\rangle$ is distributed, party A_i performs

a local Clifford gate $U^{(i)}$ on its n_i qubits. Then for every $j = 1, \dots, n$, the observable Z_j is measured on $|\Psi'\rangle = \bigotimes_{i=1}^N U^{(i)} |\Phi_{\mathcal{G}}^+\rangle$. Equivalently, we can define the Pauli operators $g_j := \prod_{i=1}^N U^{(i)\dagger} Z_j \prod_{i=1}^N U^{(i)}$ and envision these as being performed directly on the network state $|\Phi_{\mathcal{G}}^+\rangle$; the generated distribution $p(\mathbf{b}_1, \dots, \mathbf{b}_N)$ will be the same since

$$\langle \Psi' | \bigotimes_{j=1}^n (\mathbb{I} + (-1)^{b_j} Z_j) | \Psi' \rangle = \langle \Phi_{\mathcal{G}}^+ | \bigotimes_{j=1}^n (\mathbb{I} + (-1)^{b_j} g_j) | \Phi_{\mathcal{G}}^+ \rangle.$$

Our goal is to construct a classical model that generates the distribution $p(\mathbf{b}_1, \dots, \mathbf{b}_N)$ using the same network structure \mathcal{G} . To avoid confusion, in what follows, we will use an overline to distinguish classical random variables from hermitian operators; i.e. $\overline{B}, \overline{X}, \overline{Y}$, etc.. The following proposition states that a collection of binary random variables can be characterized in terms of their parity checks.

Proposition 2. Let $\{\overline{B}_1, \dots, \overline{B}_n\}$ be a collection of random variables with \overline{B}_i having value $b_i \in \mathbb{Z}_2$. For any subset of indices $S \subset [n]$, let $\overline{B}_S := \sum_{i \in S} \overline{B}_i$ denote the parity of variables specified by S , where the addition is taken modulo two. Then the joint pmf $p(b_1, \dots, b_n)$ for the \overline{B}_i is uniquely determined by the probabilities $Pr\{\overline{B}_S = 0\}$ for $S \in 2^{[n]}$.

A proof of this proposition is provided in the Appendix. Note that if $p(b_1, \dots, b_n)$ is obtained by measuring a stabilizer state, then $Pr\{\overline{B}_S = 0\} = Pr\{g_S = +1\}$ where $g_S := \prod_{i \in S} g_i$, where \overline{B}_i is the random variable corresponding to measurement outcome b_i . Hence, by Proposition 2, a classical model will correctly simulate the distribution $p(b_1, \dots, b_n)$ if it yields random variables $\{\overline{B}_1, \dots, \overline{B}_n\}$ whose parity checks \overline{B}_S have the same distribution as the corresponding product Pauli observables g_S . The $\{g_S\}_{S \in 2^{[n]}}$ form a commuting group of observables, and by properties of stabilizer measurements [30], $Pr\{g_S = +1\} = 1$ if $g_S \in \text{stab}(|\Phi_{\mathcal{G}}^+\rangle)$, $Pr\{g_S = -1\} = 1$ if $-g_S \in \text{stab}(|\Phi_{\mathcal{G}}^+\rangle)$, and $Pr\{g_S = +1\} = \frac{1}{2}$ if $\pm g_S \notin \text{stab}(|\Phi_{\mathcal{G}}^+\rangle)$.

It will be important to distinguish the elements g_S for which $+g_S \in \text{stab}(|\Phi_{\mathcal{G}}^+\rangle)$ from the g_S for which $-g_S \in \text{stab}(|\Phi_{\mathcal{G}}^+\rangle)$ [32]. Let G be the subgroup of the $\{g_S\}_{S \in 2^{[n]}}$ such that $\pm g_S \in \text{stab}(|\Phi_{\mathcal{G}}^+\rangle)$. An independent set of generators for G can always be found, and among these generators, consider the g_S such that $-g_S \in \text{stab}(|\Phi_{\mathcal{G}}^+\rangle)$. There exists an n -qubit Pauli g_0 that under conjugation flips the overall sign on each of these from -1 to $+1$, while leaving the $+1$ sign of the other generators unchanged (Prop. 10.4 in [30]). Thus, $g_0 g_S g_0^\dagger \in \text{stab}(|\Phi_{\mathcal{G}}^+\rangle)$ for all $g_S \in G$, and $g_S \in \text{stab}(|\Phi_{\mathcal{G}}^+\rangle)$ if $[g_S, g_0] = 0$ while $-g_S \in \text{stab}(|\Phi_{\mathcal{G}}^+\rangle)$ if $\{g_S, g_0\} = 0$.

We now describe a classical model that reproduces these correlations. For each g_k , let $\phi_X(g_k) \subset [n]$ denote the set of qubit registers for which g_k acts upon by

applying a Pauli- X , and similarly for $\phi_Y(g_k)$ and $\phi_Z(g_k)$. Note that all the qubits identified in these three sets are held by the same party since g_k is formed by applying a local unitary. The classical model is then the following:

- (a) For each edge $e \in \mathcal{G}$, let $\lambda_e = (\bar{X}_e, \bar{Y}_e, \bar{Z}_e)$ be a trio of independent Bernoulli random variables, each being distributed uniformly over \mathbb{Z}_2 .

(b) Let

$$\begin{aligned} \bar{B}_k = & \sum_e |e \cap \phi_X(g_k)| \cdot \bar{X}_e + \sum_e |e \cap \phi_Y(g_k)| \cdot \bar{Y}_e \\ & + \sum_e |e \cap \phi_Z(g_k)| \cdot \bar{Z}_e + \mathcal{I}(\{g_k, g_0\}) \pmod{2}, \end{aligned}$$

where $\mathcal{I}(\{g_k, g_0\}) = 1$ if $\{g_k, g_0\} = 0$ and $\mathcal{I}(\{g_k, g_0\}) = 0$ if $[g_k, g_0] = 0$.

Let us verify that this model correctly reproduces the distribution $p(\mathbf{b}_1, \dots, \mathbf{b}_N)$. As argued above, it suffices to show that $Pr\{\bar{B}_S = 0\} = Pr\{g_S = +1\}$ for all $S \in 2^{[n]}$. Observe that $\text{stab}(|\Phi_{\mathcal{G}}^+\rangle)$ is generated by the disjoint pairs $\{X_i X_j, Z_i Z_j\}$ for every $(i, j) \in E$. Therefore, $\pm g_S \in \text{stab}(|\Phi_{\mathcal{G}}^+\rangle)$ iff for every $e \in E$ the three sums $\sum_{k \in S} |e \cap \phi_X(g_k)|$, $\sum_{k \in S} |e \cap \phi_Y(g_k)|$, and $\sum_{k \in S} |e \cap \phi_Z(g_k)|$ all vanish when taken modulo 2. Hence, if $g_S \in \text{stab}(|\Phi_{\mathcal{G}}^+\rangle)$, then $\bar{B}_S = \sum_{k \in S} \bar{B}_k = \sum_{k \in S} \mathcal{I}(\{g_k, g_0\})$; by the definition of g_0 , this sum equals 0 iff g_0 commutes with g_S , and so $Pr\{\bar{B}_S = 0\} = Pr\{g_S = +1\} \in \{0, 1\}$. On the other hand, if $g_S \notin \text{stab}(|\Phi_{\mathcal{G}}^+\rangle)$ then \bar{B}_S will be a sum of at least one independent Bernoulli variable, and so $Pr\{\bar{B}_S = 0\} = Pr\{g_S = +1\} = \frac{1}{2}$.

During the completion of this manuscript we became aware of a similar model independently derived by Matthew Pusey in Ref. [4], although it does not directly account for network constraints and the emergence of network nonlocality. \square

Discussion. Theorem 1 is perhaps best understood as a guide for identifying which quantum resources are needed to generate different forms of network nonlocality. It says that building distributions using the four-step process of a Clifford network is insufficient to generate any type of network nonlocality. However, once we start broadening these three steps to allow for slightly more capabilities, then certain forms of nonlocality can emerge. Specifically, let us consider what happens when we relax the key steps (i) and (iii) in generating a Clifford network distribution. In both cases we find that Theorem 1 no longer holds.

Turning first to step (iii) and the restriction to Clifford gates, the most subtle relaxation would be to allow for classically-controlled local Clifford gates. That is, each party A_i is able to measure a subset of locally held qubits M_i , and then conditioned on the measurement outcome

\mathbf{m}_i , a Clifford gate $U_{\mathbf{m}_i}$ is performed on the remaining qubits. In principle, one could allow for multiple rounds of operations like this in step (iii). This type of sequential local processing is also known as (classical) local wiring [22, 33, 34], and it plays a fundamental role in certain resource theories of nonlocality [35–37].

When defining Clifford k -network distributions above, why did we not allow for local wiring? The reason is that by allowing for local wiring one can easily violate Theorem 1 using so-called *disguised* Bell nonlocality [12]. The latter refers to network nonlocal distributions $p(\mathbf{b}_1, \dots, \mathbf{b}_N)$ that are mere manifestations or superficial extensions of bipartite Bell nonlocality [8, 10, 38, 39]. One definite example of disguised Bell nonlocality is due to Fritz [40], who showed how any instance of standard Bell nonlocality can be converted into 2-network nonlocality by local wiring; essentially the choice of local measurement at each node becomes a classical control variable shared with some other party on the network. Using Fritz’s construction, it is then possible to generate 2-network nonlocality in Clifford networks if local wiring is permitted. This follows from the existence of nonlocal games, such as Mermin’s magic square game [41, 42], that can be won using Pauli measurements and stabilizer states with greater probability than any local hidden variable strategy. However, much of the recent focus on quantum networks has been devoted to finding examples of nonlocality that are *not* reducible to a construction like Fritz’s. These undisguised forms of Bell nonlocality are often said to embody *genuine* network nonlocality, which is understood to be a fundamentally different form of nonlocality unique to networks [43]. Indeed, Ref. [37] defines genuine network nonlocality as that which cannot be obtained through local wiring, otherwise it would be reducible to a standard Bell inequality violation. So far, all purported examples of genuine network nonlocality [15–19] can be built using a protocol matching steps (i)–(iv) in our definition of Clifford network distributions; i.e. an entangling measurement is performed at each measurement node without any classical wiring. Our main result says that Clifford networks are not strong enough to generate genuine network nonlocality in this way. [44]

Finally, let us consider relaxing step (i), the restriction of $|\varphi_e\rangle$ being a stabilizer state. Suppose on the contrary that non-stabilizer states could be used but we still require local Clifford gates in step (iii). By invoking the theory of magic states [45], it becomes possible to perform any type of local measurement, and hence all known examples of genuine network nonlocality can be realized. However, suppose we relax step (i) by allowing for *mixed* stabilizer states; i.e. convex combinations of stabilizer states. Remarkably, now it becomes possible to violate Theorem 1 using disguised Bell nonlocality. The construction is presented in the Appendix and again involves extending the magic square game to the network setting using a slight modification of Fritz’s idea. This result

highlights the strong non-convexity that emerges in network nonlocality: local models can be constructed for all pure stabilizer states, but this fails to be possible when taking their mixture. One may be tempted to think that the classical randomness in the mixed state ρ_e could just be absorbed into the classical randomness distributed on edge e . However, this does not always work since the local classical strategy for some party A_i in simulating a Clifford network distribution might depend on which state $|\varphi_e\rangle$ is seeded on edge e , even if A_i is not connected on e .

In summary, by allowing for either local wiring or mixed stabilizer states, it becomes possible to generate network nonlocality in Clifford networks. However, these additional operational capabilities appear only useful for generating disguised Bell nonlocality, and we conjecture that they are still not strong enough to produce genuine network nonlocality, given that all known examples utilize some non-Clifford operation. Ultimately, we hope these findings help pinpoint the precise differences between genuine and non-genuine quantum network nonlocality.

Let us finally remark on the difference between Theorem 1 and the Gottesman-Knill Theorem. The latter provides a classical algorithm to correctly reproduce the outcome statistics when locally measuring a stabilizer state. However, in this algorithm, one must update the generators of the stabilizer after simulating the measurement of each qubit. This requires the communication of global information, which is forbidden in the network nonlocality model. Hence, the conclusion of Theorem 1 stands independently of the Gottesman-Knill Theorem, despite them sharing a kindred spirit.

Acknowledgments – We thank Marc-Olivier Renou for discussing with us the subtleties of disguised network nonlocality. We are also grateful to Mark Howard, Jonathan Barrett, Nicolas Brunner, and Matthew Pusey for bringing several precursor works to our attention and discussing other connections between Clifford circuits and local classical models. This material is based upon work supported by the U.S. Department of Energy Office of Science National Quantum Information Science Research Centers.

APPENDIX

k-Network Nonlocality through post-selection

Here we provide more detailed proofs for some of the claims made in the main text. We begin with Proposition 1, restated here for convenience.

Proposition. Suppose that $p(\mathbf{b}_1, \dots, \mathbf{b}_N)$ is a quantum k -network nonlocal distribution for N parties. Then there exists an $(N + r)$ -party distribution

$\hat{p}(\mathbf{b}_1, \dots, \mathbf{b}_N, \mathbf{x}_1, \dots, \mathbf{x}_r)$ that is quantum 2-network nonlocal and satisfies

$$p(\mathbf{b}_1, \dots, \mathbf{b}_N) = \hat{p}(\mathbf{b}_1, \dots, \mathbf{b}_N | \mathbf{x}_1 = 0, \dots, \mathbf{x}_r = 0).$$

In other words, conditioned on the new parties X_1, \dots, X_r having the all-zero output, the other N parties reproduce the original distribution p .

Proof. Let $p(\mathbf{b}_1, \dots, \mathbf{b}_N)$ be a k -network nonlocal distribution built on some quantum network $\mathcal{G} = (V, E)$. Set $r = |E|$. For each $e \in E$, let us introduce a new party X_e who holds bipartite entanglement with each of the parties in e . In doing this, we are replacing each hyperedge of size $l \leq k$ in \mathcal{G} by l bipartite edges in a new graph. The bipartite entanglement is sufficiently large so that it can be used to distribute the original k -partite state ρ_e from X_e to all the other parties via teleportation. In this new network, the parties A_1, \dots, A_N perform the same local measurement as they did in \mathcal{G} , while parties X_1, \dots, X_r perform the teleportation measurements obtaining outcomes $(\mathbf{x}_1, \dots, \mathbf{x}_r)$. This generates a quantum 2-network distribution $\hat{p}(\mathbf{b}_1, \dots, \mathbf{b}_N, \mathbf{x}_1, \dots, \mathbf{x}_r)$. In the teleportation measurement, let 0_e denote the outcome in which party X_e projects onto the maximally entangled state. When all the X_e obtain this outcome, then the post-measurement state for parties A_1, \dots, A_N is $\otimes_{e \in E} \rho_e$. Hence, their conditional distribution is exactly the original,

$$\hat{p}(\mathbf{b}_1, \dots, \mathbf{b}_N | 0_1, \dots, 0_r) = p(\mathbf{b}_1, \dots, \mathbf{b}_N). \quad (7)$$

Now suppose that $\hat{p}(\mathbf{b}_1, \dots, \mathbf{b}_N, \mathbf{x}_1, \dots, \mathbf{x}_r)$ is 2-network local so that it has the form of Eq. (1) for some graph $\mathcal{G}' = (V', E')$. Let X_e denote the collection of edges in E' that are connected to party X_e . Then $\hat{p}(\mathbf{b}_1, \dots, \mathbf{b}_N, 0_1, \dots, 0_r)$ is equal to

$$\sum_{\vec{\lambda}} \hat{p}(\vec{\lambda}) \prod_{i=1}^N \hat{p}(\mathbf{b}_i | \bigcup_{\substack{e' \\ \text{such that} \\ i \in e'}} \lambda_{e'}) \prod_{e=1}^r \hat{p}(0_e | \bigcup_{e' \in X_e} \lambda_{e'}), \quad (8)$$

where $\hat{p}(\vec{\lambda}) = \prod_{e' \in E'} p(\lambda_{e'})$. Note that since each X_e is correlated with at most k parties in the distribution \hat{p} , we can assume without loss of generality $|X_e| \leq k$ for all e . Moreover, the extra parties X_e are pairwise uncorrelated, and so we can also assume that the X_e are pairwise disjoint sets that provide a partitioning for E' . Hence, $\hat{p}(\vec{\lambda}) = \prod_{e=1}^r \prod_{e' \in X_e} p(\lambda_{e'})$, and we can write the conditional probability $\hat{p}(\mathbf{b}_1, \dots, \mathbf{b}_N | 0_1, \dots, 0_r)$ as

$$\sum_{\vec{\lambda}} \prod_{i=1}^N \hat{p}(\mathbf{b}_i | \bigcup_{\substack{e' \\ \text{such that} \\ i \in e'}} \lambda_{e'}) \prod_{e=1}^r \frac{\hat{p}(0_e | \bigcup_{e' \in X_e} \lambda_{e'})}{\hat{p}(0_e)} \prod_{e' \in X_e} p(\lambda_{e'}), \quad (9)$$

where $\hat{p}(0_1, \dots, 0_r) = \hat{p}(0_1) \cdots \hat{p}(0_r)$ due to the independence. By Bayes' rule we can invert the conditional probabilities of 0_e ,

$$\frac{\hat{p}(0_e | \bigcup_{e' \in X_e} \lambda_{e'})}{\hat{p}(0_e)} \prod_{e' \in X_e} \hat{p}(\lambda_{e'}) = \hat{p}(\bigcup_{e' \in X_e} \lambda_{e'} | 0_e).$$

Since $|X_e| \leq k$, we have therefore constructed a classical model for generating $p(\mathbf{b}_1, \dots, \mathbf{b}_N)$ using k -partite random variables $\vec{\lambda}_e := (\lambda_{e'})_{e' \in X_e}$ with respective distributions $p(\vec{\lambda}_e | 0_e)$. This contradicts the assumption that p is k -network nonlocal. Hence, it must be the case that \hat{p} is 2-network nonlocal. \square

Clifford gates without ancilla

The next lemma shows that to generate network non-locality, it suffices to consider local Clifford gates without any ancilla.

Lemma 1. Every Clifford k -network correlation $p(\mathbf{b}_1, \dots, \mathbf{b}_N)$ generated using local ancilla can also be generated using local classical post-processing and no local ancilla systems.

Proof. Let $|\Psi\rangle^{A_1 \cdots A_N}$ be an N -partite stabilizer state with stabilizer $\text{stab}(|\Psi\rangle)$. For an arbitrary party A_i , consider the effect when all other parties perform local Clifford gates with ancilla and then measure their qubits. When all the other parties append their local ancilla systems, the overall state $|\Psi\rangle|0\rangle_1 \cdots |0\rangle_{m-m_i}$ has stabilizer $\text{stab}(|\Psi\rangle) \cup \{Z_1, \dots, Z_{m-m_i}\}$. The application of local Cliffords will then generally mix these two sets of generators, and the new state $|\Psi'\rangle$ of $t = (n+m-m_i)$ qubits will have stabilizer $\text{stab}(|\Psi'\rangle) = \langle g_1, g_2, \dots, g_t \rangle$. Each qubit is then measured in the Z -basis.

Recalling how Pauli measurements work in the stabilizer formalism [30], if $Z_k \in \text{stab}(|\Psi'\rangle)$, then its outcome is determined and we can use Z_k as one of the stabilizer generators. On the other hand, if $Z_k \notin \text{stab}(|\Psi'\rangle)$, then we can find a set of generators for $\text{stab}(|\Psi'\rangle)$ such that Z_k anti-commutes with one and only of of them. The measurement outcome on qubit k is equivalent to an unbiased coin flip, and we replace the anti-commuting element with $(-1)^{b_k} Z_k$, where $(-1)^{b_k}$ is the measurement outcome of Z_k and $b_k \in \{0, 1\}$. The post-measurement state thus has an updated stabilizer, and the measurement outcome on any other qubit will either be another random coin flip or it will depend on the value b_k .

Suppose that the measurement of parties $A_1 \cdots A_{i-1} A_{i+1} \cdots A_N$ obtains the specific sequence of outcomes $\mathbf{b}_{\bar{i}} = (\mathbf{b}_1, \dots, \mathbf{b}_{i-1}, \mathbf{b}_{i+1}, \dots, \mathbf{b}_N)$. The post-measurement state for system A_i is a stabilizer state $|\psi_{\mathbf{b}_{\bar{i}}}\rangle^{A_i}$ with stabilizer $\langle (-1)^{d_1} g_1, \dots, (-1)^{d_{n_i}} g_{n_i} \rangle$,

in which the bit values $d_l \in \{0, 1\}$ are determined by the particular sequence $\mathbf{b}_{\bar{i}}$. Crucially, the outcomes $\mathbf{b}_{\bar{i}}$ of the other parties only affect the ± 1 factors on the generators g_i of $\text{stab}(|\psi_{\mathbf{b}_{\bar{i}}}\rangle)$. Party A_i then introduces m_i local ancilla systems and performs a Clifford across the joint state $|\Psi_{\vec{x}_i}\rangle^{A_i} |0\rangle_1 \cdots |0\rangle_{m_i}$. This will generate a transformation in the stabilizer of the form

$$\begin{aligned} & \langle (-1)^{d_1} g_1, \dots, (-1)^{d_{n_i}} g_{n_i} \rangle \cup \langle Z_1 \cdots Z_{m_i} \rangle \\ \rightarrow & \langle (-1)^{d_1} g'_1, \dots, (-1)^{d_{n_i}} g'_{n_i}, h_1, \dots, h_{m_i} \rangle. \end{aligned} \quad (10)$$

Party A_i then measures the $t_i = n_i + m_i$ qubits. With the g'_l and h_l being fixed by the initial state $|\Psi\rangle$ and choice of local Cliffords for all the parties, each outcome sequence $\mathbf{b}_i = (b_1, \dots, b_{t_i})$ for party A_i is obtained according to some conditional distribution $p(\mathbf{b}_i | \mathbf{d})$. Since the values $\mathbf{d} = (d_1, \dots, d_{n_i})$ are a function of the sequence $\mathbf{b}_{\bar{i}}$, we have

$$p(\mathbf{b}_i | \mathbf{d}) = p(\mathbf{b}_i | \mathbf{b}_{\bar{i}}). \quad (11)$$

An equivalent protocol for party A_i that generates the same outcome distribution with no ancilla involves measuring each of the generators $\{g_l\}_{l=1}^{n_i}$ directly on the state $|\Psi_{\mathbf{b}_{\bar{i}}}\rangle^{A_i}$, thereby learning the sequence \mathbf{d} . The party then generates the outcome sequence \mathbf{b}_i by classical sampling according to the conditional distribution $p(\mathbf{b}_i | \mathbf{d})$. Since $p(\mathbf{b}_1, \dots, \mathbf{b}_n) = p(\mathbf{b}_i | \mathbf{b}_{\bar{i}}) p(\mathbf{b}_{\bar{i}})$ and $p(\mathbf{b}_i | \mathbf{d}) = p(\mathbf{b}_i | \mathbf{b}_{\bar{i}})$, this new protocol reproduces the correct global distribution. As A_i was an arbitrary party, we can perform this modified protocol for all parties thereby removing any use of ancilla systems. \square

Joint distribution is determined by parity of subsets

Next, we provide a self-contained proof for Proposition 2, which says that the joint distribution of n binary random variables is characterized by the parity of all possible subsets.

Proposition. Let $\{\bar{B}_1, \dots, \bar{B}_n\}$ be a collection of random variables with \bar{B}_i having value $b_i \in \mathbb{Z}_2$. For any subset of indices $S \subset [n]$, let $\bar{B}_S := \sum_{i \in S} \bar{B}_i$ denote the parity of variables specified by S , where the addition is taken modulo two. Then the joint pmf $p(b_1, \dots, b_n)$ for the \bar{B}_i is uniquely determined by the probabilities $Pr\{\bar{B}_S = 0\}$ for $S \in 2^{[n]}$.

Proof. Let P and Q be probability distributions over n -bit strings having the same probabilities for every parity check.

Proceeding by induction, assume that the proposition holds for any distributions over $(n-1)$ -bit strings or fewer. Observe that the parity check on any marginal of P is also in the set of parity checks of P . Then the parity

checks on the marginals P' of P are equivalent to those Q' of Q obtained by taking the same marginalization. Since P' and Q' are over $(n-1)$ -bit strings or fewer, our assumption implies that $P' = Q'$. That is, the probability distributions of the marginals are the same if P and Q have the same parity checks. It remains to prove that $P = Q$.

Suppose $P \neq Q$. Then there exists a n -bit sequence x such that $P(x) \neq Q(x)$. Without loss of generality, assume that x has even parity, and $P(x) < Q(x)$. Flipping a single bit of x yields another sequence y with odd parity. Then $P(x) + P(y)$ is the marginalization of P with respect to that bit. Then, from our assumption, $P(x) + P(y) = Q(x) + Q(y)$. This implies $P(y) > Q(y)$. Continuing to flip one bit at a time, we get $P(x') < Q(x')$ for every even-parity bit string x' , and $P(y') > Q(y')$ for every odd-parity string y' . Summing all the even-parity probabilities, we get $\sum_{x'} P(x') < \sum_{x'} Q(x')$. But the sum is a parity check over all n -bits, which our assumption demands to be the same for P and Q . Thus, by contradiction, we have $P = Q$ whenever $P' = Q'$ for marginals over $(n-1)$ -bit strings or fewer.

The one-bit case $P(x_1) = Q(x_1)$ trivially serves as a base for our induction step. We conclude that, for every $n \in \mathbb{N}$, the parity check probabilities $Pr\{\overline{B}_S = 0\}$, for $S \in 2^{[n]}$, uniquely determine a pmf $P(b_1, \dots, b_n)$, where \overline{B}_S is the parity of the variables specified by S . \square

Clifford networks with mixed states

Finally, we show that network nonlocality can be realized using *mixed* stabilizer states. However, we stress that our construction represents a disguised form of bipartite Bell nonlocality, as opposed to genuine network nonlocality, since it uses Fritz's network extension [40] of the magic square game [41, 42]. A summary of the types of network nonlocality that can be generated in Clifford Networks under various relaxations on the allowed operations is provided in Table I.

Proposition. Network nonlocality can be generated using mixed stabilizer states and Clifford gates.

Proof. In a slight abuse of notation, we consider a scenario in which Alice and Bob each hold locally four systems (A_1, A_2, A_{12}, A_X) and (B_1, B_2, B_{12}, B_Y) , respectively. Systems $A_1, A_2, B_1,$ and B_2 are each qubits, while A_{12} and B_{12} are two-qubit systems. Systems A_X and B_Y are classical registers. In the magic square game, Alice and Bob share two Bell states $|\Phi^+\rangle_{A_1 B_1} |\Phi^+\rangle_{A_2 B_2}$, with $|\Phi^+\rangle = \frac{1}{\sqrt{2}}(|00\rangle + |11\rangle)$. They perform local measurements specified by the following 3×3 grid:

$$\begin{pmatrix} \mathbb{I} \otimes Z & Z \otimes \mathbb{I} & Z \otimes Z \\ X \otimes \mathbb{I} & \mathbb{I} \otimes X & X \otimes X \\ -X \otimes Z & -Z \otimes X & Y \otimes Y \end{pmatrix}.$$

In the game, Bob is asked to make a measurement on systems $B_1 B_2$ described by one of these nine observables. Alice is asked to measure on systems $A_1 A_2$ all the observables along one of the rows or along one of the columns. Thus, Alice returns a triple of ± 1 values. Notice that each row/column defines a particular "context" for Bob's observable. Consequently, the game can be equivalently described by having Alice measure in one of six orthogonal bases, each one being a common eigenbasis to the observables along a row or column. After measuring in the given basis, she can determine the triple of ± 1 values to report using her measurement outcome. For example, the observables in the second column have a common eigenbasis of $\{|0\rangle|+\rangle, |0\rangle|-\rangle, |1\rangle|+\rangle, |1\rangle|-\rangle\}$. When she projects in this basis, she outputs three values of ± 1 based on whether the projected state is a ± 1 eigenstate of $Z \otimes \mathbb{I}, \mathbb{I} \otimes X,$ and $-Z \otimes X,$ respectively. The crucial observation for the protocol we describe below is that each eigenbasis defined by a row/column in the above square is invariant under local Paulis (up to overall ± 1 phases).

Consider a line network of four nodes: X, A, B, Y. Between A and B is shared the state $|\Phi^+\rangle_{A_1 B_1} |\Phi^+\rangle_{A_2 B_2}$. Let $x \in \{1, \dots, 6\}$ enumerate the three rows and three columns in the grid. Then, between X and A is shared the mixed state

$$\rho^{XA} = \frac{1}{6} \sum_{x=1}^6 |x\rangle\langle x|^X \otimes |x\rangle\langle x|^{A_x} \otimes |e_x\rangle\langle e_x|^{A_{12}}, \quad (12)$$

where $|e_x\rangle^{A_{12}}$ is any one of the four basis elements belonging to the common eigenbasis of row/column x . For instance in the example above, we could take $|e_5\rangle = |0\rangle|+\rangle$, with $x = 5$ denoting the second column of the grid. Likewise for Bob, let $y \in \{1, \dots, 9\}$ enumerate all the elements in the grid. Then, between Y and B is shared the mixed state

$$\rho^{YB} = \frac{1}{9} \sum_{y=1}^9 |y\rangle\langle y|^Y \otimes |y\rangle\langle y|^{B_y} \otimes \frac{1}{4} (\mathbb{I} \otimes \mathbb{I} + g_y)^{B_{12}}, \quad (13)$$

where g_y is the Pauli observable in cell y of the grid. Alice and Bob each perform two Bell measurements across systems $A_{12} : A_1 A_2$ and $B_{12} : B_1 B_2$, respectively. They also measure systems A_X and B_Y , respectively, so that they know which observables they are measuring on the quantum systems. This information is correlated with parties X and Y, respectively, since they have access to the classical registers.

For Alice, the Bell measurements will project system A_{12} onto $A_1 A_2$ up to some Pauli errors, and likewise system B_{12} gets projected onto $B_1 B_2$ up to Pauli errors. In the case of Alice, as noted above, the Pauli errors will just alter which one of the four basis states gets projected. Since Alice knows the basis x , she can always correct these Pauli error classically. To see how this works, it is easiest to consider a concrete example. Suppose that

Type of Nonlocality	Type of Clifford Network		
	No wiring & pure states	Wiring & pure states	No wiring & mixed states
Genuine Network Nonlocality	No (Theorem 1)	No (Definition in Ref. [37])	??
Disguised Bell Nonlocality	No (Theorem 1)	Yes (Fritz's construction [40])	Yes (Fritz's construction [40])

TABLE I. Type of nonlocality in different kinds of Clifford networks. The answer for whether genuine network nonlocality is allowed in the scenario with wiring and pure states is dependent on its definition. That answer is "No" by the definition in Ref. [37], which hinges on the describability of the correlations through local wiring. The question marks also depend on the definition adopted, and to our knowledge they can only be resolved upon further characterization of the genuine network nonlocality scenarios prescribed by different definitions. We conjecture that genuine network nonlocality cannot be achieved in a scenario with mixed states and no wiring - that is, the answer to the question marks will be "No."

Alice measures $x = 5$ on register A_X with $|e_x\rangle = |0\rangle|+\rangle$, while her Bell measurements return an X error on A_1 and a Z error on A_2 . The effective projection on systems A_1A_2 is then $(Z \otimes X)|e_x\rangle\langle e_x|(Z \otimes X) = |1\rangle\langle 1| \otimes |-\rangle\langle -|$, which is another one of the elements in basis $x = 5$. Hence, to correctly play the magic square game, Alice needs to only return the values corresponding to a $|1\rangle\langle -|$ projection; i.e. she returns $(-1, -1, -1)$. A similar correction is performed by Bob based on his outcome of the Bell measurement. In total, Alice and Bob correctly reproduce the quantum strategy of playing the magic square game, and their choices of measurements are independently correlated with separate nodes X and Y . The generated distribution is thus quantum 2-network nonlocal [40]. \square

simple approach and generalization to arbitrary dimensions, Phys. Rev. Lett. **106**, 020405 (2011).

* amandag6@illinois.edu

† echitamb@illinois.edu

- [1] D. Gottesman, The heisenberg representation of quantum computers (1998), arXiv:quant-ph/9807006.
- [2] S. Aaronson and D. Gottesman, Improved simulation of stabilizer circuits, Phys. Rev. A **70**, 052328 (2004).
- [3] S. Anders and H. J. Briegel, Fast simulation of stabilizer circuits using a graph-state representation, Phys. Rev. A **73**, 022334 (2006).
- [4] M. Pusey, *A few connections between Quantum Computation and Quantum Non-Localiry*, Master's thesis, Imperial College London (2010).
- [5] T. E. Tessier, C. M. Caves, I. H. Deutsch, B. Eastin, and D. Bacon, Optimal classical-communication-assisted local model of n -qubit greenberger-horne-zeilinger correlations, Phys. Rev. A **72**, 032305 (2005).
- [6] M. Howard and J. Vala, Nonlocality as a benchmark for universal quantum computation in ising anyon topological quantum computers, Phys. Rev. A **85**, 022304 (2012).
- [7] M. Howard, Maximum nonlocality and minimum uncertainty using magic states, Phys. Rev. A **91**, 042103 (2015).
- [8] C. Branciard, N. Gisin, and S. Pironio, Characterizing the nonlocal correlations created via entanglement swapping, Phys. Rev. Lett. **104**, 170401 (2010).
- [9] J.-D. Bancal, N. Brunner, N. Gisin, and Y.-C. Liang, Detecting genuine multipartite quantum nonlocality: A
- [10] C. Branciard, D. Rosset, N. Gisin, and S. Pironio, Bilocal versus nonbilocal correlations in entanglement-swapping experiments, Phys. Rev. A **85**, 032119 (2012).
- [11] N. Gisin, Entanglement 25 years after quantum teleportation: Testing joint measurements in quantum networks, Entropy **21**, 325 (2019).
- [12] A. Tavakoli, A. Pozas-Kerstjens, M.-X. Luo, and M.-O. Renou, Bell nonlocality in networks, Reports on Progress in Physics **85**, 056001 (2022).
- [13] N. Brunner, D. Cavalcanti, S. Pironio, V. Scarani, and S. Wehner, Bell nonlocality, Rev. Mod. Phys. **86**, 419 (2014).
- [14] M. Navascués, E. Wolfe, D. Rosset, and A. Pozas-Kerstjens, Genuine network multipartite entanglement, Phys. Rev. Lett. **125**, 240505 (2020).
- [15] M.-O. Renou, E. Bäumer, S. Boreiri, N. Brunner, N. Gisin, and S. Beigi, Genuine quantum nonlocality in the triangle network, Phys. Rev. Lett. **123**, 140401 (2019).
- [16] A. Tavakoli, N. Gisin, and C. Branciard, Bilocal bell inequalities violated by the quantum elegant joint measurement, Phys. Rev. Lett. **126**, 220401 (2021).
- [17] M.-O. Renou and S. Beigi, Network nonlocality via rigidity of token counting and color matching, Phys. Rev. A **105**, 022408 (2022).
- [18] M.-O. Renou and S. Beigi, Nonlocality for generic networks, Phys. Rev. Lett. **128**, 060401 (2022).
- [19] A. Pozas-Kerstjens, N. Gisin, and A. Tavakoli, Full network nonlocality, Phys. Rev. Lett. **128**, 010403 (2022).
- [20] A. Pozas-Kerstjens, N. Gisin, and M.-O. Renou, Proofs of network quantum nonlocality aided by machine learning (2022), arXiv:2203.16543.
- [21] S. Popescu and D. Rohrlich, Quantum nonlocality as an axiom, Foundations of Physics **24**, 379 (1994).
- [22] A. J. Short, S. Popescu, and N. Gisin, Entanglement swapping for generalized nonlocal correlations, Phys. Rev. A **73**, 012101 (2006).
- [23] M. Forster and S. Wolf, Bipartite units of nonlocality, Phys. Rev. A **84**, 042112 (2011).
- [24] R. Chaves and C. Budroni, Entropic nonsignaling correlations, Phys. Rev. Lett. **116**, 240501 (2016).
- [25] E. Wolfe, R. W. Spekkens, and T. Fritz, The inflation technique for causal inference with latent variables, Journal of Causal Inference **7**, 10.1515/jci-2017-0020 (2019).
- [26] M.-O. Renou, Y. Wang, S. Boreiri, S. Beigi, N. Gisin, and N. Brunner, Limits on correlations in networks for quan-

- tum and no-signaling resources, *Phys. Rev. Lett.* **123**, 070403 (2019).
- [27] N. Gisin, J.-D. Bancal, Y. Cai, P. Remy, A. Tavakoli, E. Z. Cruzeiro, S. Popescu, and N. Brunner, Constraints on nonlocality in networks from no-signaling and independence, *Nature Communications* **11**, 10.1038/s41467-020-16137-4 (2020).
- [28] P. Bierhorst, Ruling out bipartite nonsignaling nonlocal models for tripartite correlations, *Phys. Rev. A* **104**, 012210 (2021).
- [29] D. Gottesman, Stabilizer codes and quantum error correction (1997), arXiv:quant-ph/9705052.
- [30] M. A. Nielsen and I. L. Chuang, *Quantum Computation and Quantum Information* (Cambridge University Press, 2000).
- [31] D. Fattal, T. S. Cubitt, Y. Yamamoto, S. Bravyi, and I. L. Chuang, Entanglement in the stabilizer formalism (2004), arXiv:quant-ph/0406168.
- [32] Note, it is not possible for both $+g_s \in \text{stab}(|\Phi_G^+\rangle)$ and $-g_s \in \text{stab}(|\Phi_G^+\rangle)$ since $-\mathbb{I} \notin \text{stab}(|\Phi_G^+\rangle)$.
- [33] J. Barrett, Information processing in generalized probabilistic theories, *Phys. Rev. A* **75**, 032304 (2007).
- [34] J. Allcock, N. Brunner, N. Linden, S. Popescu, P. Skrzypczyk, and T. Vértesi, Closed sets of nonlocal correlations, *Phys. Rev. A* **80**, 062107 (2009).
- [35] R. Gallego, L. E. Würflinger, A. Acín, and M. Navascués, Operational framework for nonlocality, *Phys. Rev. Lett.* **109**, 070401 (2012).
- [36] J. I. de Vicente, On nonlocality as a resource theory and nonlocality measures, *Journal of Physics A: Mathematical and Theoretical* **47**, 424017 (2014).
- [37] I. Šupić, J.-D. Bancal, Y. Cai, and N. Brunner, Genuine network quantum nonlocality and self-testing, *Phys. Rev. A* **105**, 022206 (2022).
- [38] K. Mukherjee, B. Paul, and D. Sarkar, Correlations in n -local scenario, *Quantum Information Processing* **14**, 2025 (2015).
- [39] A. Tavakoli, M. O. Renou, N. Gisin, and N. Brunner, Correlations in star networks: from bell inequalities to network inequalities, *New Journal of Physics* **19**, 073003 (2017).
- [40] T. Fritz, Beyond bell's theorem: correlation scenarios, *New Journal of Physics* **14**, 103001 (2012).
- [41] N. D. Mermin, Simple unified form for the major no-hidden-variables theorems, *Phys. Rev. Lett.* **65**, 3373 (1990).
- [42] R. Cleve, P. Hoyer, B. Toner, and J. Watrous, Consequences and limits of nonlocal strategies, in *Proceedings. 19th IEEE Annual Conference on Computational Complexity, 2004.* (2004) pp. 236–249.
- [43] M. F. Pusey, Quantum correlations take a new shape, *Physics* **12**, 10.1103/physics.12.106 (2019).
- [44] Any quantum network distribution generated by local wiring can also be generated by local entangling measurements and no local wiring. However, not every classically-controlled Clifford gates admits a unitary dilation that itself is Clifford. Consequently our model prevents transforming Fritz's construction for hidden nonlocality into a protocol that can be implemented in a Clifford network with classical local wiring.
- [45] S. Bravyi and A. Kitaev, Universal quantum computation with ideal clifford gates and noisy ancillas, *Phys. Rev. A* **71**, 022316 (2005).